

WM-3001
6" HD LCD Waveform Monitor

Instruction Manual

March 18, 2002
Ver. 2.00

Video Operations Division
ASTRODESIGN, INC.



Contents

Contents.....	1
INTRODUCTION.....	3
SAFETY PRECAUTIONS	4
CHAPTER 1 INTRODUCTION TO WM-3001	7
1.1 Outline of WM-3001	7
1.2 Functions of WM-3001	7
CHAPTER 2 PARTS AND THEIR FUNCTIONS.....	10
2.1 WM-3001's Front View and Components	10
2.2 WM-3001's Rear View and Components	11
CHAPTER 3 CONNECTIONS	13
3.1 Connections	13
CHAPTER 4 OPERATION	14
4.1 Operating the Monitor	14
4.2 Performing Mode-by-mode Operations and Using Switches	14
4.2.1 Switches Common to All Modes (Fixed-function Switches)	15
4.2.2 Picture Mode	17
4.2.3 Waveform Mode	18
4.2.4 Vectorscope Mode	23
4.2.5 Status Mode	25
4.2.6 Menu Mode	27
4.3 Schematic Hierarchy of Switches	30
4.4 Installing and Anchoring the Monitor	32
CHAPTER 5 MAIN SPECIFICATIONS	33
5.1 Input Formats.....	33
5.2 Methods of Signal Input	35
5.3 Methods of Display	35
5.4 General Specifications	35
5.5 Initial Settings.....	36
5.6 Dimensional Drawings	39
CHAPTER 6 STANDARD AND OPTIONAL ACCESSORIES.....	40
6.1 Standard Accessories	40
6.2 Optional Accessories	40
Attaching the LCD Protection Panel Supplied as a Standard WM-3001 Accessory	41
Data Sheet of DM-3000A-03 AC/DC Adapter	42
Instructions on the Use of DM-3000A-04 Single Rack Mounting Brackets	43
Instructions on the Use of DM-3000A-05 Double Rack Mounting Brackets	44
Instructions on the Use of DM-3000A-08 Shading Hood	45

INTRODUCTION

Thank you very much for purchasing Model WM-3001 HD LCD Waveform Monitor. This manual contains details on the operation procedures to be followed when the WM-3001 is used, the checkpoints and precautions to be observed, and other information.

Improper handling may result in malfunctioning. Therefore, before using the WM-3001, please read through these instructions to gain an understanding on how to operate the waveform monitor correctly. After reading through the manual, keep it in a safe place for future reference.

SAFETY PRECAUTIONS

WARNING

CONCERNING THE POWER CORD

- Always take hold of the molded part of the plug when disconnecting the power cord.
- Do not excessively bend or tightly coil the power cord, as this may damage the cord and eventually cause a fire.
- Do not place heavy objects on top of the power cord, as this may damage the cord and eventually cause a fire or electrical shock.

CONCERNING FOREIGN MATTER

- Do not spill liquids, or drop flammable substances or metal parts into the monitor, as this may cause a fire, electric shocks, or malfunctioning.

DO NOT DISASSEMBLE THE MONITOR!

- The monitor contains high-voltage parts. Touching these parts is extremely dangerous and may result in electric shocks or burns.

CAUTION

CONCERNING THE POWER SUPPLY

- Use a supply voltage within the range of 10 V to 18 V.
- Do not turn the power back on immediately after having turned it off. Doing so can cause malfunctioning.

CONCERNING INSTALLATION

- Ensure that the following conditions for the installation location are satisfied in order to ensure that the monitor will be used properly.
 - 1) Avoid locations where strong magnetic fields and/or vibration is generated, very dusty locations or locations exposed to water or chemicals.
 - 2) Avoid locations exposed to direct sunlight and locations susceptible to extreme changes in humidity or air temperature.
 - 3) Connect the monitor's power plug to a power outlet separate from the one used for equipment with a high power consumption such as a copier or one for equipment that generates noise.
 - 4) Do not place heavy objects such as a CRT monitor directly on top of this unit.
 - 5) Avoid placing anything directly up against the monitor's rear panel. Doing so will block the ventilation holes in the rear panel so that the monitor may not operate properly even when its temperature is within the acceptable ambient range.

CONCERNING IMPACT

- This is a precision instrument and, as such, subjecting it to impact may cause malfunctioning. Take special care when moving the monitor.

CONCERNING THE LIQUID CRYSTAL DISPLAY PANEL

- The LCD panel is a high-precision part and, as such, the following care must be taken in its handling.
 - 1) Wiping the panel's surface with benzine, paint thinners, etc. will cause deterioration in its quality.
 - 2) If water (salty water) is left on the display surface, discoloration and staining will result.
 - 3) Exposing the panel directly to ultraviolet rays for an extended period may cause the deflection panel to turn brown, the contrast to drop and other forms of deterioration in the display quality.
 - 4) Moisture inside the monitor due to condensation, etc. may cause unevenness in the colors.
 - 5) Due to the nature of liquid crystal, some picture elements may be missing (bright spots or dark spots).
 - 6) Directly tapping the surface or bumping it into objects will cause cracking, etc.
 - 7) Do not attempt to disassemble the panel, as leaking liquid crystal may be harmful if it comes into contact with your skin.
 - 8) If you are exposed to liquid crystal because tube surface has broken, rinse it off well with soap and water.

CONCERNING THE OPERATION LOCATION

- If the monitor is used indoors, no special care need be taken. However, installation in the following locations can cause malfunctioning.
 - 1) Locations with an ambient temperature outside the range of 5 to 40°C
 - 2) Locations with an ambient humidity outside the range of 30 to 80% RH
 - 3) Locations near an air conditioner or subject to rapid temperature changes or the formation of condensation
 - 4) Locations exposed to direct sunlight (*1)
 - 5) Locations exposed to corrosive gases or high concentrations of dust
 - 6) Locations where strong magnetic fields are generated
 - 7) Locations which may be splashed with water, oil, chemicals, etc.
 - 8) Very dusty locations or locations to which vibrations are transmitted from the floor
 - 9) Unstable locations

*1: Since the panel's backlight may be damaged when the surface temperature of the LCD panel exceeds 60°C, keep the panel away from direct sunlight.

WHEN TROUBLE OR MALFUNCTIONING OCCURS

- In the unlikely event that trouble or malfunctioning should occur, contact your dealer or an Astrodesign sales representative.
- If trouble occurs in the LCD panel, the user will be charged for repairs and parts replacement even within one year after delivery.

CONCERNING THIS MANUAL

- It is strictly forbidden to copy this manual either in part or in its entirety without permission from Astrodesign.
 - 1) The contents and specifications of this manual are subject to change without notice for the purposes of improving quality.
 - 2) Although this manual has been prepared with painstaking care, the user is asked to contact Astrodesign if any ambiguities, mistakes, omissions or other shortcomings are noticed.
 - 3) The shortcomings in 2) notwithstanding, Astrodesign will not be liable in any way for their effects on the results achieved by operating the monitor.

CHAPTER 1 INTRODUCTION TO WM-3001

1.1 Outline of WM-3001

The WM-3001 is an HDTV waveform monitor which is compact, lightweight, and portable and which is designed to monitor the pictures being shot during live broadcasts, on location or in studios, etc.

The monitor can also be powered by the camera battery pack, so pictures can be viewed absolutely anywhere.

The monitor comes with a number of modes: the picture mode in which the input video is displayed in color, the waveform mode which displays it as waveforms, the vectorscope mode that displays it as vectors, and the status mode in which the data is dumped.

A low-temperature polysilicon thin-film transistor (TFT) LCD panel is used for the monitor's display.

The input signals support 20 different video formats in all, including 19 HDTV formats and one SDTV format. HDTV SDI and SDTV SDI digital signals and HDTV analog signals can easily be selected. An HDTV SDI signal refers to a 1.485 Gbps NRZ serial digital signal, while an SDTV SDI signal refers to a 270 Mbps NRZ serial digital signal. The formats supported for HDTV are 1080/60i, 1035/60i, 720/60p, 720/24p, 1080/24p, 1080/24sF, 1080/30p, 1080/30sF, 1080/25p, 1080/25sF and 1080/50i. For SDTV, the WM-3001 supports the 525/60i format with frequency rates of 1.000 and 1/1.001. The field frequencies (60/59.94 Hz, 24/23.98 Hz, etc.) of each format are automatically supported.

- Six-inch low-temperature polysilicon TFT LCD panel
- Lightweight and compact size (3U half-size)
- 12 V DC power supply (10 to 18 V)
- Operable on camera battery
- Supported standards of HDTV SDI input: SMPTE 292M, BTAS-004B, and BTAS-006B (1.485 Gbps SDI input)
- Supported standards of HDTV SDI audio input: SMPTE 299M
- Supported standards of SDTV SDI input: SMPTE 259M (270 Mbps SDI input)
- Supported standards of HDTV analog input and its format: SMPTE 274M, SMPTE 296M, and BTAS-001B

1.2 Functions of WM-3001

- Compatible with HDTV SDI and SDTV SDI digital input and HDTV analog input (Y/Pb/Pr) signals
 - ◆ HDTV SDI input: Signals compatible with SMPTE 292M, etc. are input to and viewed on the monitor (with MONITOR OUT terminal).
 - No-signal/CRCC error count readings (0 to 999999999, or ***** for higher counts)
 - Readings of time for last CRCC error detection (LAST) (up to 99 hours 59 minutes 59 seconds, or * for longer times)

- ◆ SDTV SDI input: Signals compatible with SMPTE 259M, etc. are input to and viewed on the monitor (with MONITOR OUT terminal).
- ◆ HDTV analog input: YPbPr signals (Y_On Sync) compatible with BTAS-001B are input to and viewed on the monitor.
- Supports 20 different video formats
(HDTV: 1080/60i, 1080/24p, 1080/24sF, 1080/30p, 1080/30sF, 1080/25p, 1080/25sF, 1080/50i, 1035/60i, 720/60p, and 720/24p; SDTV: 525/50i)
- Automatically supports the field frequency rates of 60 Hz, 60/1.001 Hz, etc.
- Displays the format and field frequency rate of an input signal and the format selected for output.
- Displays the time elapsed from reset (TIME) (up to 99 hours 59 minutes 59 seconds, or * for longer times)
- The POWER LED comes on when the power is turned on.
- The ERROR LED comes on if an error occurs in the input signal or when no input signal is supplied.
- Outputs a BLACK signal when input signals are absent.
- Supports two-channel tally signal input (driven by external contacts; the red or green LED lamp above the screen comes on upon input of a TALLY signal).
- Overlay function (superimposes an input picture on top of another)
- Freeze/update function
- Allows for selection from of a choice of five modes: menu mode, picture mode, waveform mode, vectorscope mode, and status mode.
 - ◆ Picture mode: Displays input pictures in color
 - Displays markers (center marker, and frame marker with safety marker; aspect ratios of 4:3, 13:9, 14:9 and 2.4:1)
 - Video adjustments using brightness, contrast, Pb (Cb), Pr (Cr), and chroma controls
 - Turns on/off CHROMA option.
 - ◆ Waveform mode: Displays the waveforms of input pictures.
 - Overlay display (overlays the waveforms of Y/Pb (Cb)/Pr (Cr) or G/B/R signals on top of each other)
 - Parade display (places the waveforms of Y/Pb (Cb)/Pr (Cr) or G/B/R signals next to one another) (for 1H- and 1F-sweep displays only)
 - 1H/2H/1F/2F-sweep displays (2H/2F-sweep displays are for the interlace format only)
 - Line select function for displaying desired lines (for 1H/2H-sweep displays only)
 - Shows markers in mV or % increments
 - GAIN (×1, ×2, or ×4); MAG (×1, ×2, or ×4) (for 1H-sweep overlay display only)
 - Measures amplitude or time differences between waveforms using cursor (time differences are only available for 1H/2H-sweep displays)
 - Converts Y/Pb/Pr (YCbCr) to G/B/R for display as GBR pictures
 - ◆ Vectorscope mode: Displays input pictures in vectorscope images
 - Magnifies black and white levels (×1, ×2, or ×4)
 - 100% and 75% color bars for markers
 - Choice of two scales: XY and IQ axes
 - Line select function for displaying desired lines

- ◆ Status mode: Sequentially displays digital values obtained from arbitrarily sampled lines of input pictures.
 - Allows for single-action movement to EAV/SAV position.
 - Can display not only video data but also auxiliary data for sampled lines.
 - Indicates audio levels in a bar graph (only when HDTV SDI signals are input).

- ◆ Menu mode
 - Sets the mode of input signals (SDI or ANALOG).
 - Sets the format.
 - Sets the values of BRIGHT, CONTRAST, Pb (Cb), Pr (Cr) and CHROMA options.
 - Selects from the CHROMA ON/OFF options.
 - Sets the value of CONTRAST for the overlay mode display of input video (NORMAL/DIM).
 - Sets the waveform display (YP (YC) or GBR).
 - Sets the scale of the waveform display (% or V).
 - Selects a marker for vectorscope mode display (100% or 75%).
 - Resets the error count.
 - Calls up the saved settings, saves settings, and initializes the settings.

CHAPTER 2 PARTS AND THEIR FUNCTIONS

2.1 WM-3001's Front View and Components

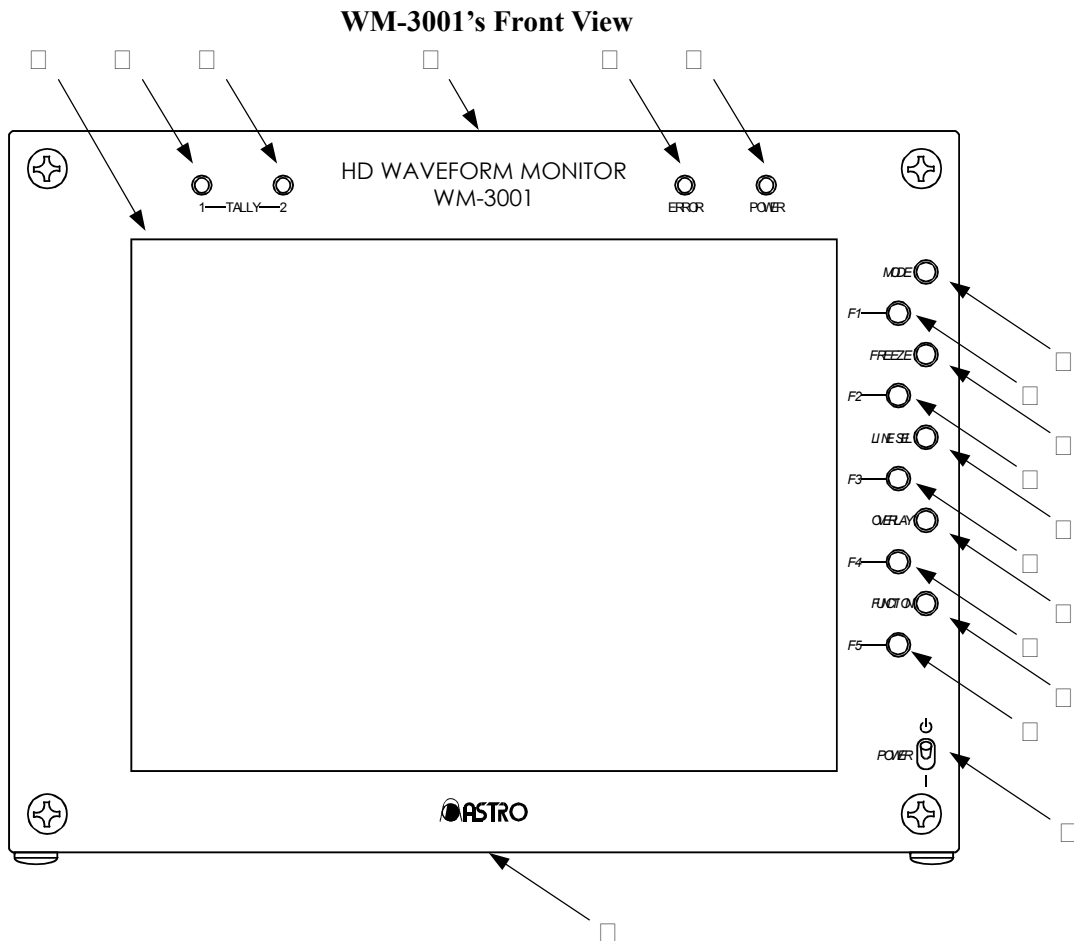

Front-panel Components and Their Functions

Number	Component	Description of Function	
<input type="checkbox"/>	Liquid crystal display	Displays pictures.	
<input type="checkbox"/>	TALLY 1	TALLY lamp (red): controlled by rear-panel tally connector (contact-driven).	
<input type="checkbox"/>	TALLY 2	TALLY lamp (green): controlled by rear-panel tally connector (contact-driven).	
<input type="checkbox"/>	ERROR LED	ERROR lamp (red): comes on when there are no input signals or when an error occurs.	
<input type="checkbox"/>	POWER LED	POWER lamp (green): comes on when the power is supplied.	
<input type="checkbox"/>	MODE (*2)	Shows a menu of modes to select from.	*2: These switches have fixed functions. For further details, see "Common to all modes (fixed function switches)" in subsection 4.2.1.
<input type="checkbox"/>	FREEZE (*2)	Switches between the FREEZE and UPDATE options.	
<input type="checkbox"/>	LINE SEL (*2)	Shows a menu of lines to select from.	
<input type="checkbox"/>	OVERLAY (*2)	Sets the picture overlay function to ON or OFF.	
<input type="checkbox"/>	FUNCTION (*2)	Shows a menu of functions to select from.	
<input type="checkbox"/>	F1 (*3)	FUNCTION 1	*3: These switches provide different functions depending on the mode. For further details, see the operation method of each mode described in subsections 4.2.2 to 4.2.6.
<input type="checkbox"/>	F2 (*3)	FUNCTION 2	
<input type="checkbox"/>	F3 (*3)	FUNCTION 3	
<input type="checkbox"/>	F4 (*3)	FUNCTION 4	
<input type="checkbox"/>	F5 (*3)	FUNCTION 5	

□	POWER	Switches between the power-on and stand-by states.
□	3/8" threaded hole	Screw hole for anchoring the monitor onto a tripod, arm, etc.

2.2 WM-3001's Rear View and Components

WM-3001's Rear View

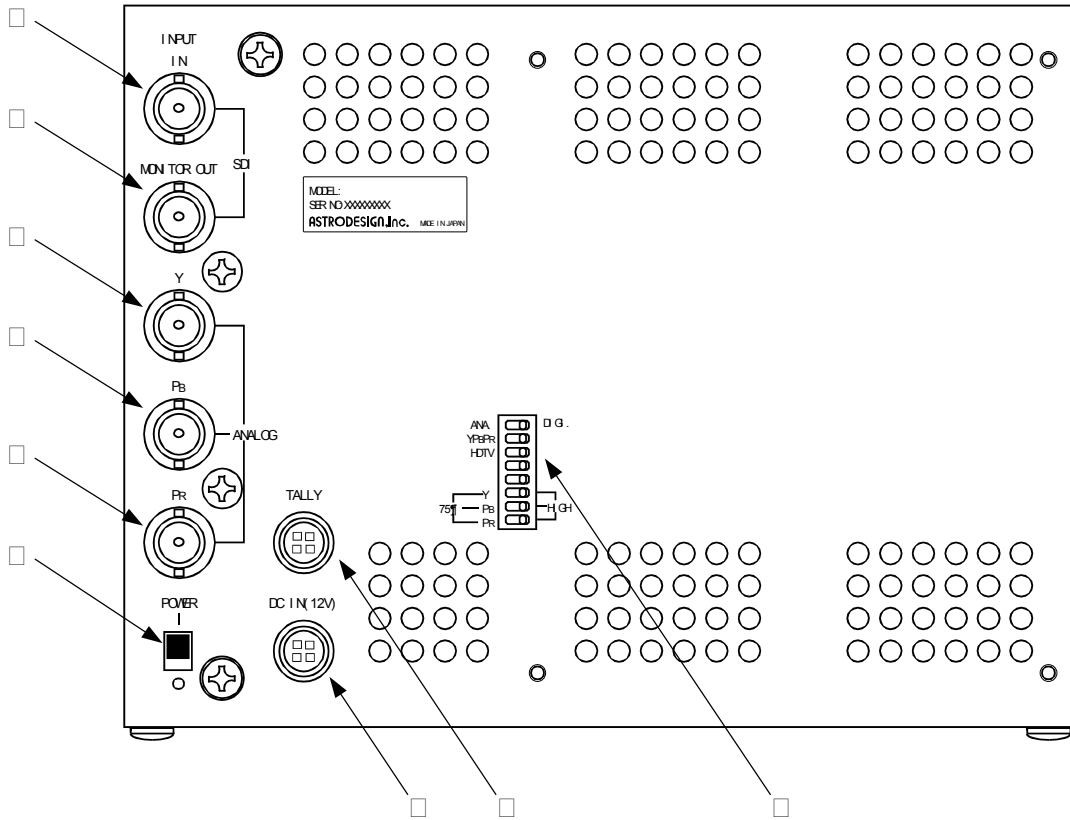



Rear-panel Components and Their Functions

Number	Component	Description of Function
□	SDI IN	Input terminal for HDTV SDI and SDTV SDI signals
□	SDI MONITOR OUT	Output terminal for simplified monitoring of input signals
□	ANALOG Y	Input terminal for the Y signal of HDTV analog input. For HDTV analog input, synchronization is achieved by means of the Y signal.
□	ANALOG Pb	Input terminal for the Pb signal of HDTV analog input
□	ANALOG Pr	Input terminal for the Pr signal of HDTV analog input
□	POWER	Turns on/off the power.
□	Power supply connector	Four-pin, round male camera connector for 12 V input (GND: pin 1; 12 V: pin 4).
□	TALLY connector (*4)	Four-pin, round female camera connector (TALLY 1 (red): pins 1 and 4; TALLY 2 (green): pins 2 and 3).
□	Termination selector switch	Switches between the terminating resistors of YPbPr signal input.

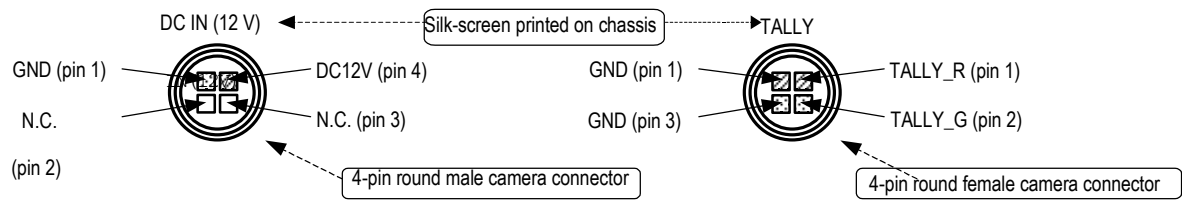
*4 Power supply and TALLY connectors



- The pin assignments of the power supply and tally connectors are as shown in the figure above (power supply connector on the left and tally connector on the right). Be careful, as the two connectors have different pin assignments even though they look identical.
- To turn on the TALLY 1 (red) lamp, short-circuit the pins marked .
- To turn on the TALLY 2 (green) lamp, short-circuit the pins marked .

CHAPTER 3 CONNECTIONS

3.1 Connections

This section describes how to wire the WM-3001.

(1) Connecting the power supply

Connect the power supply to the round camera connector serving as a power supply connector (Ⓢ in the rear view). This connector has 4 pins: pin 1 (GND), pin 4 (DC input) and pins 2 and 3 (no connection). Either the accessory cable (4-pin round camera connector/cannon connector conversion cable) or the optional (*) DC input cable (DM-3000A-09) is available for the power supply connector. Check the configuration of your cable end connector prior to use.

(2) Connecting the source of input signals

When inputting HDTV SDI or SDTV SDI signals, connect the signal source to the SDI terminal using a BNC coaxial cable. The IN terminal is used to input SDI signals, and the MONITOR OUT terminal is used to monitor the SDI signals being input. Supply BTAS-004B or SMPTE 259M compatible serial digital signals to the SDI input terminal. For SDI signals, use a coaxial cable (5C-FB or equivalent) capable of handling the 1.5 GHz band.

When inputting HDTV analog signals, connect the sources of Y, Pb and Pr signals to the ANALOG Y, ANALOG Pb and ANALOG Pr terminals, respectively. Supply BTAS-001B compatible Y/Pb/Pr signals to the ANALOG input terminal. Synchronization is achieved by means of the Y signal.

(3) Setting

Use the menu mode to set up input signals and their formats. Also make other settings as necessary. Do not change the settings of the rear-panel DIP switch unless you need to change the terminating resistor.

* For details on optional accessories see Chapter 6, Section 6.2, "Optional Accessories."

CHAPTER 4 OPERATION

4.1 Operating the Monitor

First check that the WM-3001 is wired and set up correctly. Then, turn on the rear-panel POWER switch of the WM-3001. The POWER lamp comes on, and the monitor displays the input picture.

If the green POWER lamp fails to come on, check that the front-panel POWER switch is turned on. If the green POWER lamp still remains off, check the connections once again.

If the screen looks distorted or runs out of synchronization, check the FORMAT settings. For simple monitoring of the SDI input signals, monitor them at the MONITOR OUT terminal. The analog input signals will not provide any picture unless the Y signal contains a synchronization signal. For details on the signal level and other specifications, refer to BTAS-001 or other standards.

When there are no input signals, the ERROR LED lamp comes on, and the text BLACK is displayed.

If an HDTV SDI signal is being input, the ERROR LED lamp also comes on even in the case of CRC error.

If the screen displays “NO SIGNAL” even if an input signal is applied, check the settings of the menu mode.

Note that data values presented for analog input are for reference purposes only and should be used as rule-of-thumb values.

4.2 Performing Mode-by-mode Operations and Using Switches

The WM-3001 has five modes: the menu mode, picture mode, waveform mode, vectorscope mode and status mode.

There are two types of switches: switches with functions that do not vary with mode, and switches whose functions vary mode by mode. For details on operations, refer to the description of each mode on the following pages.

4.2.1	Switches Common to All Modes (Fixed-function Switches)	15
4.2.2	Picture Mode	17
4.2.3	Waveform Mode	18
4.2.4	Vectorscope Mode	23
4.2.5	Status Mode	25
4.2.6	Menu Mode	27

4.2.1 Switches Common to All Modes (Fixed-function Switches)

- The functions of the following switches are common to all modes.
- Note that some switches are not available depending on the mode.

Switch Name	Number Marked in Front View	Description of Function
MODE	<input type="checkbox"/>	Turns on/off the menu of modes to select from.
FREEZE	<input type="checkbox"/>	Switches between the FREEZE and UPDATE options of input pictures.
LINE SEL	<input type="checkbox"/>	Turns on/off the menu of lines to select from.
OVERLAY	<input type="checkbox"/>	Turns on/off the picture overlay function.
FUNCTION	<input type="checkbox"/>	Turns on/off the menu of functions to select from.

- **MODE:** Shows a menu of modes to select from.
The texts PICTURE, WAVEFORM, VECTOR, STATUS and MENU appear on the screen next to the F1, F2, F3, F4 and F5 switches, respectively. Pressing the F1 to F5 switches in this order with these texts on screen moves through the picture mode, waveform mode, vectorscope mode, status mode, and menu mode. This switch can be used in any of the operation modes.

- **FREEZE:** Switches between the FREEZE and UPDATE options of input pictures.

The text FREEZE is shown in reverse video at the top of the LCD display as long as the input picture is kept frozen. Input video data at that point is retained. This switch can be used in any of the operation modes.

Note: Do not change the input video format or input channel during freeze, as this may cause the monitor to malfunction.

- **LINE SEL:** Enables you to select a line to monitor.

This switch can only be used in the waveform and vectorscope modes. The numbers of the selected line and field appear in the upper-right corner of the screen.

For HDTV signal input, the numbers read as shown below:

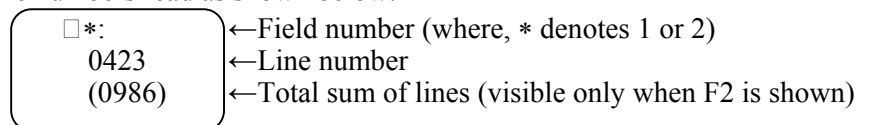

For SDTV signal input, the numbers read as shown below:

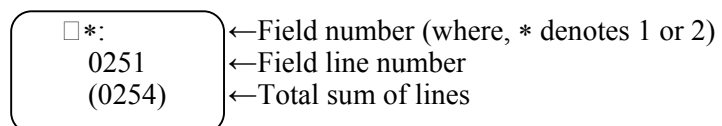

If you turn on the picture overlay function when the LINE SEL switch is on, the position of the selected line is indicated on the overlay picture.

- **OVERLAY:** Outputs the input picture onto the background. This switch cannot be used in the picture mode.

If you set the OVERLAY CONT option of the menu mode to NORMAL (default), a pre-adjusted input picture is output onto the background.

If you set the OVERLAY CONT option of the menu mode to DIM, the overlay picture of a mode

other than the menu mode is output onto the background at a 25% contrast level.

- **FUNCTION:** Changes the functions of the F1 to F5 switches when the monitor is in the waveform mode.

When HDTV SDI signal input is selected, the FUNCTION switch switches between data dumping and audio monitoring in the status mode. This switch cannot be used in any other mode.

4.2.2 Picture Mode

- This mode displays input pictures in color.
- In this mode, you can only work with the on-screen markers (center marker, and frame marker with an aspect ratio of 4:3, 13:9, 14:9, or 2.4:1).
- The name of a selected marker is shown in reverse video.
- Use the menu mode to adjust pictures using the brightness, contrast, Pb (Cb), Pr (Cr), and chroma controls or show/hide the chroma control.

Switch Name	Number Marked in Front View	Description of Function
F1	<input type="checkbox"/>	Turns on/off the center marker.
F2	<input type="checkbox"/>	Turns on/off the frame marker (16:9) and safety marker (16:9 [90%]).
F3	<input type="checkbox"/>	Selects from the 4:3/13:9/14:9 markers.
F4	<input type="checkbox"/>	Turns on/off the 2.4:1 marker.
F5	<input type="checkbox"/>	Turns on/off the menu of functions.

- ◆ F1: Shows the cross marker in the middle of the picture view area.
(CENTER)
- ◆ F2: Shows the frame marker (solid outline) and safety marker (dotted outline) in the picture view area. The frame marker has an aspect ratio of 16:9, and the safety marker is shown inside the frame marker at 90% the size thereof.
(FRAME)
- ◆ F3: Selects from the 4:3/13:9/14:9 markers (vertical lines). Each press of this switch cycles through the 4:3, 13:9, and 14:9 markers.
(4:3/13:9/14:9)
- ◆ F4: Shows the 2.4:1 marker (horizontal line).
(2.4:1)
- ◆ F5: Shows the menu of the functions (cursor names) of the F1 to F4 switches.
(FUNCTION DISPLAY)

Note: Care must be taken since when the 1035 format is used, each of the center marker, the frame marker, and the 4:3, 13:9, 14:9, and 2.4:1 markers takes a 1080 format value.

4.2.3 Waveform Mode

- By default, this mode displays a 1H-sweep waveform of input video. You can select from the 1H, 2H, 1F, and 2F sweep options for the waveform to be displayed. Note that you can select the 2H and 2F-sweep displays only when the input video is in the interlace format or segment frame format.)
- You can select a Y/Pb/Pr (YCbCr) or G/B/R signal to display its waveforms. Use the menu mode to switch between the waveforms to be displayed.
- The overlay display function of the waveform mode overlays the Y/Pb/Pr or G/B/R waveforms.
- The parade display function of the waveform mode places the Y/Pb/Pr or G/B/R waveforms next to one another. This function presents only a 1H (1F)-sweep display even when you have selected the 2H (2F)-sweep display.
- If you change a parade display to an overlay display, the waveform mode provides only a 1H (1F)-sweep display. The mode does not retain the 2H (2F)-sweep display settings.
- The V GAIN and H MAG magnification functions are available. You can choose from $\times 1$ (default), $\times 2$, and $\times 4$ options.
- Use the H MAG magnification function for a 1H-sweep overlay display only.
- The line select function (LINE SEL switch) is available.

When this function is used, the monitor provides a 1H-sweep display (or 2H-sweep display, if this display has been selected).

- When an HDTV signal is being input, turning off the line select function results in the sampling of lines through a decimation process.
- When an SDTV signal is being input, turning off the line select function results in the sampling of all lines.
- You can use the settings of selected lines also in other modes since the settings are retained.
- The picture overlay function (OVERLAY switch) is available.

When the line select function is in use, the position of a selected line is shown on the overlay picture.

Switch Name	Number Marked in Front View	Description of Function
FUNCTION	□	Switch for driving the menu of functions. Pressing the FUNCTION switch and then one of the F1 to F5 switches selects the function of that switch. F1: DISPLAY, F2: SWEEP, F3: CURSOR, F4: GAIN/MAG, F5: SCROLL (shown only for the GAIN/MAG magnification function)

- ◆ **FUNCTION:** Switch for driving the menu of functions.
The texts DISPLAY, SWEEP, CURSOR, GAIN/MAG and SCROLL (shown only for the GAIN/MAG magnification function) appear on the screen next to the F1, F2, F3, F4, and F5 switches, respectively. Pressing one of the F1 to F5 switches when these texts are on screen shows the menu for adjusting the function of that switch.

● Functions Available when F1 (DISPLAY) Is Pressed

Switch Name	Number Marked in Front View	Description of Function
F1	<input type="checkbox"/>	Parade display
F2	<input type="checkbox"/>	Overlay display
F3	<input type="checkbox"/>	Turns on/off channel 1 (Y/G).
F4	<input type="checkbox"/>	Turns on/off channel 2 (Pb/B).
F5	<input type="checkbox"/>	Turns on/off channel 3 (Pr/R).

- ◆ F1: (PARADE) Presents a 1H/1F-sweep display of Y/Pb/Pr or G/B/R waveforms by placing them next to one another.
- ◆ F2: (OVERLAY) Shows Y/Pb/Pr or G/B/R waveforms by overlaying them on top of each other.
- ◆ F3: (Y/G) Shows the waveform of channel 1 (Y/G).
Pressing this switch with the parade display selected shows only the Y/G waveforms of the overlay display.
- ◆ F4: (Pb(Cb)/B) Shows the waveform of channel 2 (Pb(Cb)/B).
Pressing this switch with the parade display selected shows only the Pb(Cb)/B waveforms of the overlay display.
- ◆ F5: (Pr(Cr)/R) Shows the waveform of channel 3 (Pr(Cr)/R).
Pressing this switch with the parade display selected shows only the Pr(Cr)/R waveforms of the overlay display.

● Functions Available when F2 (SWEEP) Is Pressed

Switch Name	Number Marked in Front View	Description of Function
F1	<input type="checkbox"/>	Presents a 1H-sweep display of waveforms on the screen.
F2	<input type="checkbox"/>	Presents a 2H-sweep display of waveforms on the screen.
F3	<input type="checkbox"/>	Presents a 1F-sweep display of waveforms on the screen.
F4	<input type="checkbox"/>	Presents a 2F-sweep display of waveforms on the screen.
F5	<input type="checkbox"/>	—————

- ◆ F1: (1H) Presents a 1H-sweep display of waveforms on the screen.
- ◆ F2: (2H) Presents a 2H-sweep display of waveforms on the screen.
This option is selectable only when the input signal is in the interlace format or segment frame format, and not shown in the menu in the case of the progressive format.
- ◆ F3: (1F) Presents a 1F-sweep display of waveforms on the screen.
This option is selectable only when all lines are sampled, and not shown in the menu when the LINE SEL switch is set to ON.
- ◆ F4: (2F) Presents a 2F-sweep display of waveforms on the screen.
This option is selectable only when the input signal is in the interlace format or segment frame format and all lines are sampled; the option is not shown in the menu in the case of the progressive format, or the LINE SEL switch is set to ON.

● Functions Available when F3 (CURSOR) Is Pressed

Switch Name	Number Marked in Front View	Description of Function
F1	<input type="checkbox"/>	Increments the BASE, OFFSET or TRACK option.
F2	<input type="checkbox"/>	Decrements the BASE, OFFSET or TRACK option.
F3	<input type="checkbox"/>	Switches between the BASE, OFFSET and TRACK options.
F4	<input type="checkbox"/>	Switches between the cursors.
F5	<input type="checkbox"/>	_____

- ◆ F1: (INC) Moves the cursor selected by the F3 switch (for selection from BASE/OFFSET/TRACK) in the “+” direction. When TRACK is selected, this option moves both cursors. The interval between the cursors remains unchanged.
- ◆ F2: (DEC) Moves the cursor selected by the F3 switch (for selection from BASE/OFFSET/TRACK) in the “-” direction. When TRACK is selected, this option moves both cursors. The interval between the cursors remains unchanged.
- ◆ F3: (BASE/OFFSET/TRACK) Each press of this switch cycles through the BASE, OFFSET and TRACK options. The solid-line cursor is displayed for BASE and the dotted-line cursor for OFFSET. The TRACK option causes both cursors to be selected.
- ◆ F4: (CURSOR OFF/H/V) Each press of this switch cycles through the CURSOR OFF, CURSOR H (horizontal line) and CURSOR V (vertical line) options.

● Functions Available when F4 (GAIN/MAG) Is Pressed

Switch Name	Number Marked in Front View	Description of Function
F1	<input type="checkbox"/>	Switches between the options of V GAIN.
F2	<input type="checkbox"/>	Switches between the options of H MAG.
F3	<input type="checkbox"/>	_____
F4	<input type="checkbox"/>	_____
F5	<input type="checkbox"/>	_____

- ◆ F1: (GAIN $\times 1/\times 2/\times 4$) Changes the V GAIN (vertical magnification) setting. You can select from the $\times 1$, $\times 2$, and $\times 4$ options of V GAIN.
- ◆ F2: (MAG $\times 1/\times 2/\times 4$) Changes the H MAG (horizontal magnification) setting. You can select from the $\times 1$, $\times 2$, and $\times 4$ options of H MAG. This switch option is selectable only if a 1H-sweep overlay display is selected, and not shown in the menu when any other type of display is selected.

● Functions Available when F5 (SCROLL) Is Pressed

Switch Name	Number Marked in Front View	Description of Function
F1	<input type="checkbox"/>	Scrolls the magnified waveform upward.
F2	<input type="checkbox"/>	Scrolls the magnified waveform downward.
F3	<input type="checkbox"/>	Scrolls the magnified waveform to the right.
F4	<input type="checkbox"/>	Scrolls the magnified waveform to the left.
F5	<input type="checkbox"/>	Resets the point of scrolling.

- ◆ F1: (SCROLL UP) Scrolls the magnified waveform upward. This option is effective only when the $\times 2$ or $\times 4$ option of V GAIN is selected, and not shown in the menu when the $\times 1$ option is selected.
- ◆ F2: (SCROLL DOWN) Scrolls the magnified waveform downward. This option is effective only when the $\times 2$ or $\times 4$ option of V GAIN is selected, and not shown in the menu when the $\times 1$ option is selected.
- ◆ F3: (SCROLL RIGHT) Scrolls the magnified waveform to the right. This option is effective only when the $\times 2$ or $\times 4$ option of H MAG is selected, and not shown in the menu when the $\times 1$ option is selected.
- ◆ F4: (SCROLL LEFT) Scrolls the magnified waveform to the left. This option is effective only when the $\times 2$ or $\times 4$ option of H MAG is selected, and not shown in the menu when the $\times 1$ option is selected.
- ◆ F5: (RESET) Resets the point of scrolling. This option reverts the waveform to be displayed to the black-level waveform for the starting point of an on-screen picture.

● Functions Available when LINE SELECT Menu Is Enabled

Switch Name	Number Marked in Front View	Description of Function
F1	<input type="checkbox"/>	Increments the lines.
F2	<input type="checkbox"/>	Decrements the lines.
F3	<input type="checkbox"/>	Turns on/off the line select function.
F4	<input type="checkbox"/>	Switches between the fields.
F5	<input type="checkbox"/>	—————

- ◆ F1: (LINE INC) Increments the number of lines to be selected. You can specify the number and show waveforms on a 1H-sweep basis. If you select a 2H-sweep display, the monitor presents a 2H-sweep display of waveforms. This option is not shown in the menu when LINE SEL is set to OFF.
- ◆ F2: (LINE DEC) Decrements the number of lines to be selected. You can specify the number and show waveforms on a 1H-sweep basis. If you select a 2H-sweep display, the monitor presents a 2H-sweep display of waveforms. This option is not shown in the menu when LINE SEL is set to OFF.
- ◆ F3: (LINE SEL OFF/ON) Turns on/off the line select function.
- ◆ F4: (FIELD) Switches between the fields. This option is effective only when the input signal is in the interlace format

or segment frame format. This option is not shown in the menu in the case of the progressive format.

4.2.4 Vectorscope Mode

- This mode provides the vectorscope displays of input pictures.
- You can magnify the black and white levels ($\times 1$, $\times 2$, or $\times 4$).
- You can select from the 100% and 75% color bars for the markers. (Use the menu mode to select from the markers.)
- In addition to the regular XY axes, IQ axes are displayed for the scale.
- The line select function (LINE SEL switch) is available.

When this function is used, the screen presents a 1H-sweep display (or 2H-sweep display, if this display mode has been selected).

- When an HDTV signal is being input, turning off the line select function results in the sampling of lines through a decimation process.
- When an SDTV signal is being input, turning off the line select function results in the sampling of all lines.
- You can use the settings of selected lines also in other modes since the settings are retained.
- The picture overlay function (OVERLAY switch) is available.

When the line select function is in use, the position of a selected line is shown on the overlay picture.

Switch Name	Number Marked in Front View	Description of Function
F1	<input type="checkbox"/>	Increments the lines.
F2	<input type="checkbox"/>	Decrements the lines.
F3	<input type="checkbox"/>	Turns on/off the line select function.
F4	<input type="checkbox"/>	Switches between the fields.
F5	<input type="checkbox"/>	Selects from the options of black- and white-level magnification.

- ◆ F1:
(LINE INC) Increments the number of lines to be selected.
You can specify the number and show waveforms on a 1H-sweep basis. If you select a 2H-sweep display, the monitor presents a 2H-sweep display of waveforms. This option is not shown in the menu when LINE SEL is set to OFF.
- ◆ F2:
(LINE DEC) Decrements the number of lines to be selected.
You can specify the number and show waveforms on a 1H-sweep basis. If you select a 2H-sweep display, the monitor presents a 2H-sweep display of waveforms. This option is not shown in the menu when LINE SEL is set to OFF.
- ◆ F3:
(LINE SEL OFF/ON) Turns on/off the line select function. This option appears when the LINE SELECT menu is enabled (LINE SEL switch is pressed).
- ◆ F4:
(FIELD) Switches between the fields.
This option is effective only when the input signal is in the interlace format or segment frame format. This option is not shown in the menu in the case of the progressive format.
- ◆ F5:
(GAIN $\times 1/\times 2/\times 4$) Selects from the options of a channel's black- and white-level magnification.
You can select from the $\times 1$, $\times 2$ and $\times 4$ options of GAIN.

Note: The F1 to F4 options are shown only when the line select menu is enabled (LINE SEL switch is pressed).

4.2.5 Status Mode

- This mode shows the statuses (values) or audio data (bar graph).
- This mode indicates the EAV/SAV positions at the time of data dumping.
- You can also use the settings of lines selected for data dumping in other modes since the settings are retained.
- You can monitor audio data when the HDTV SDI format is selected.
- You can monitor the audio data on as many as 16 channels.
- In principle, the audio level is for reference purposes only and should be used.
- The unit dB of an audio level is represented as the ratio dBFS of the 24-bit full scale.
- The picture overlay function (OVERLAY switch) is available.
- At the time of data dumping, information on the selected position is indicated on the overlay picture.

Switch Name	Number Marked in Front View	Description of Function
FUNCTION	<input type="checkbox"/>	Switch for selecting from functions. This switch selects from the “data dumping” and “audio monitoring” options.

- ◆ FUNCTION: Switch for selecting from functions.
When the HDTV SDI format is selected, this switch switches between data dumping and audio monitoring. When the HDTV analog format or SDTV format is selected, you cannot switch to audio monitoring.

● Functions Available when Data Dumping Is Selected

Switch Name	Number Marked in Front View	Description of Function
F1	<input type="checkbox"/>	Increments the lines or samples.
F2	<input type="checkbox"/>	Decrements the lines or samples.
F3	<input type="checkbox"/>	Switches between the options “selected lines” and “starting sample.”
F4	<input type="checkbox"/>	Switches between the fields.
F5	<input type="checkbox"/>	Jumps to the EAV/SAV position.

- ◆ F1: Increments the number of lines or samples to be selected.
(LINE INC/SMPL INC)
- ◆ F2: Decrements the number of lines or samples to be selected.
(LINE DEC/SMPL DEC)
- ◆ F3: Switches between the options “selected lines” and “starting sample.”
(LINE/SAMPLE)
Turns on/off the line select function.
- ◆ F4: Switches between the fields.
(FIELD)
This option is effective only when the input signal is in the interlace format or segment frame format. This option is not shown in the menu in the case of the progressive format.
- ◆ F5: Jumps to the EAV/SAV position.

- Screen View when Audio Monitoring Is Selected

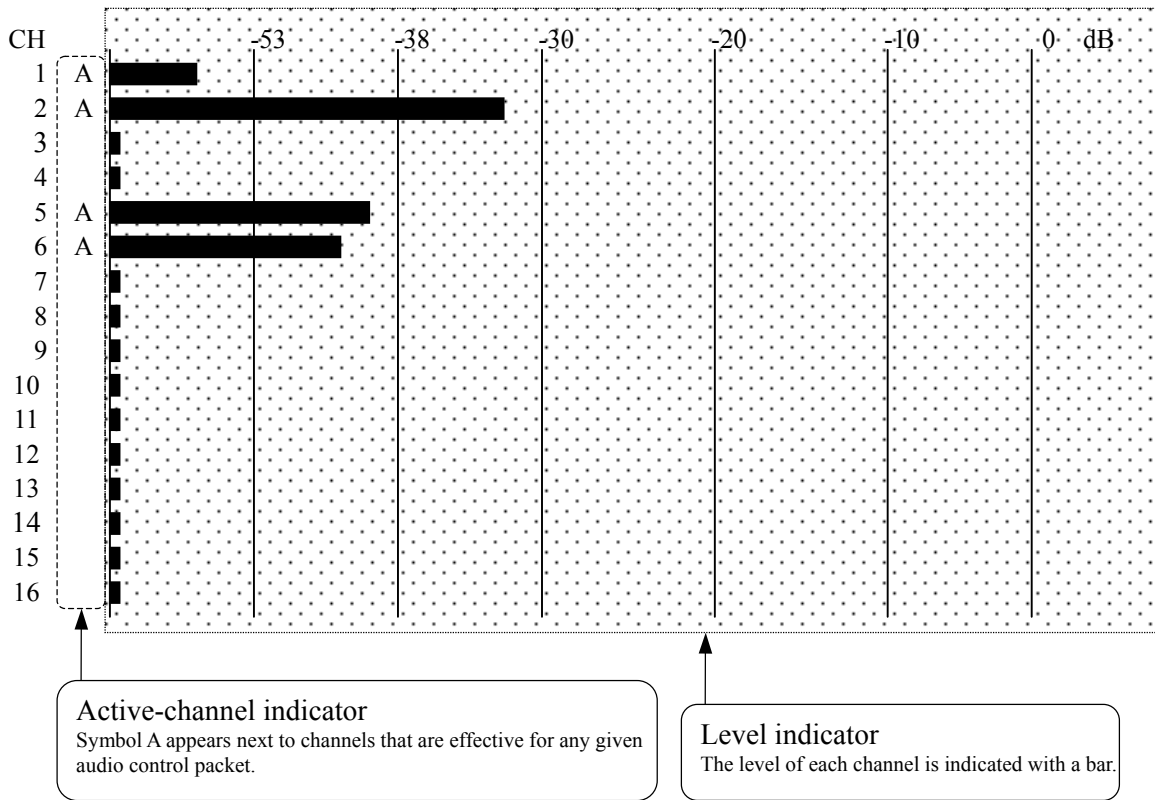

Note: The “audio monitoring” option is available only when an HDTV SDI signal is being input.

4.2.6 Menu Mode

- In this mode, you can select SDI signal input or analog YPbPr signal input.
- You can select the desired format for these inputs.
For HDTV signal input, select from:
1080/60i, 1035/60i, 720/60p, 720/24p, 1080/24p, 1080/24sF, 1080/30p, 1080/25p, and 1080/25sF;
For SDTV signal input, select 525/60i.
For the 1080/30sF format of HDTV, select 1080/60i and for the 1080/50i format of HDTV, select 1080/25sF.
- You can set the values of BRIGHT, CONTRAST, Pb(Cr), Pr(Cr), and CHROMA settings.
- You can set the CHROMA option to ON or OFF.
- For the CONTRAST setting of an overlay picture, you can switch between the value of a pre-adjusted picture and a forcibly reduced value (25%).
- You can switch between the Y/Pb/Pr settings and G/B/R settings for the waveform on display.
- The scale of waveform displays can be switched between % and V.
- You can switch between the 100% and 75% options for the marker of a vectorscope display.
- You can reset the error count.
- You can call up the saved settings, save settings, and initialize the settings.

Switch Name	Number Marked in Front View	Description of Function
F1	<input type="checkbox"/>	Moves the menu-selecting cursor up one setup item.
F2	<input type="checkbox"/>	Moves the menu-selecting cursor down one setup item.
F3	<input type="checkbox"/>	Adjusts or changes the selected setup item.
F4	<input type="checkbox"/>	Adjusts or changes the selected setup item.
F5	<input type="checkbox"/>	Executes the selected setup item.

- ◆ F1: (UP) Moves the menu-selecting cursor (> in reversed video) up one setup item.
If already at the topmost option (CHANNEL), the cursor jumps to the bottommost option (INIT SETTING).
- ◆ F2: (DOWN) Moves the menu-selecting cursor (> in reversed video) down one setup item.
If already at the bottommost option (INIT SETTING), the cursor jumps to the topmost option (CHANNEL).
- ◆ F3: Moves the menu-selecting cursor (> in reversed video) one option of the selected setup item to the left.
When the BRIGHT, CONTRAST, Pb (Cb), Pr (Cr), or CHROMA option is selected, this switch increments the value of that option.
- ◆ F4: Moves the menu-selecting cursor (> in reversed video) one option of the selected setup item to the right.
When the BRIGHT, CONTRAST, Pb (Cb), Pr (Cr), or CHROMA option is selected, this switch decrements the value of that option.
- ◆ F5: Executes the selected setup item.
The ERROR RESET, LOAD SETTING, SAVE SETTING, or INIT SETTING setup item is executed.

- CHANNEL: Select SDI or ANALOG according to the format of input signals. Note that if you select ANALOG when the format is 525/60i, the 1080/60i format is applied.
- FORMAT: Select the format that matches the format of input pictures. Note that if you have selected ANALOG, you cannot select the 525/60i format. For details on the formats see Chapter 5, “Main Specifications.”
- BRIGHT: You can set the brightness level (variable from -6.8% to +6.7%).

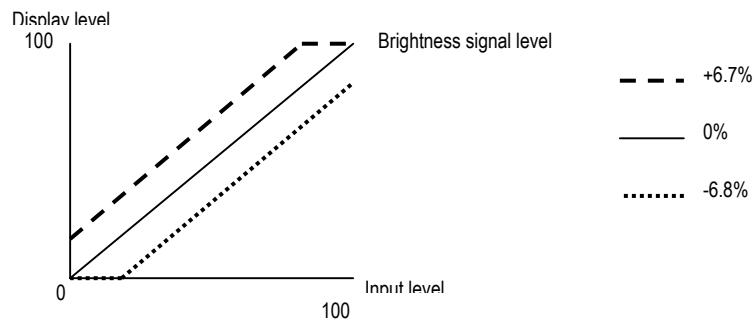

- CONTRAST: You can set a difference between brightness and darkness levels. (variable from 50% to 150%).

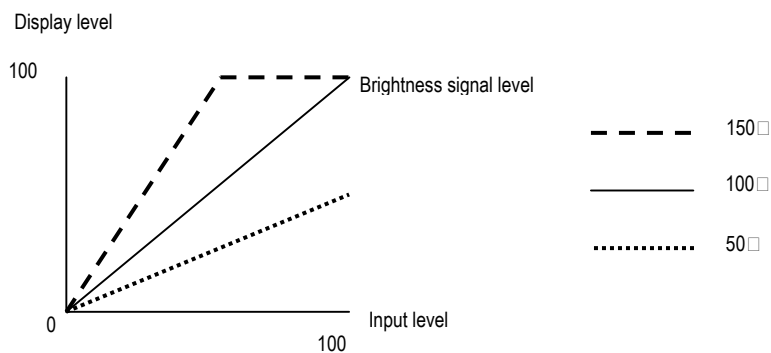

- Pb (Cb), Pr (Cr), and CHROMA: You can set the level of color-difference signals (variable from 50% to 150%). For the Pb (Cr), and Pr (Cr) options, set the Pb (Cr) and Pr (Cr) levels separately. For the CHROMA option, set the Pb (Cr), and Pr (Cr) levels at the same time.

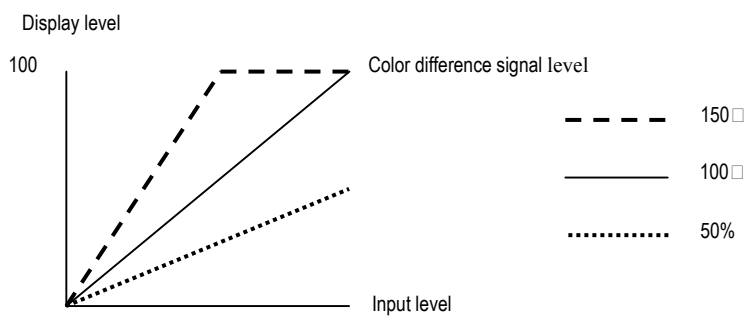

Note: If you separately set either the Pb (Cb) or Pr (Cr) level for the Pb (Cb) or Pr (Cr) option, and then set the CHROMA option, the individual Pb (Cb) and Pr (Cr) settings are cancelled. The

latest settings of these options are also cancelled if you attempt to readjust the settings after turning off the power. To keep the Pb (Cb) and Pr (Cr) levels in memory for a prolonged period, save the individual Pb (Cb) and Pr (Cr) settings when you set them up separately.

- CHROMA ON/OFF: This option turns on or off the CHROMA setup item.
 - OVERLAY CONT: This option outputs an overlay picture in modes other than the menu mode at the value of a pre-adjusted picture (NORMAL) of the CONTRAST setup item. You can also output the picture with the value of CONTRAST always decreased to 25% (DIM).
 - WAVEFORM: You can switch between the Y/Pb/Pr (YCbCr) settings and G/B/R settings for the waveform on display. Note however that YPbPr (YCbCr) is represented as YP (CP).
 - SCALE: Switches the scale of waveform displays between % and V.
 - COLOR BAR: Switches between the 100% and 75% options for the marker of a vectorscope display.
 - ERROR RESET: Resets the error count.
 - LOAD SETTING: Calls up the saved settings.
 - SAVE SETTING: Saves settings.
During saving, the text "WORKING" appears in reverse video. Do not turn off the power before this indication goes out.
- Note: Once the power is turned off, the settings of the monitor are those that were saved last. (If no settings have been saved, the monitor reverts to the default settings.) It is advisable to save the latest settings before you turn off the power.
- INIT SETTING: Initializes the settings.

4.3 Schematic Hierarchy of Switches

- When **MODE** Switch Is Pressed

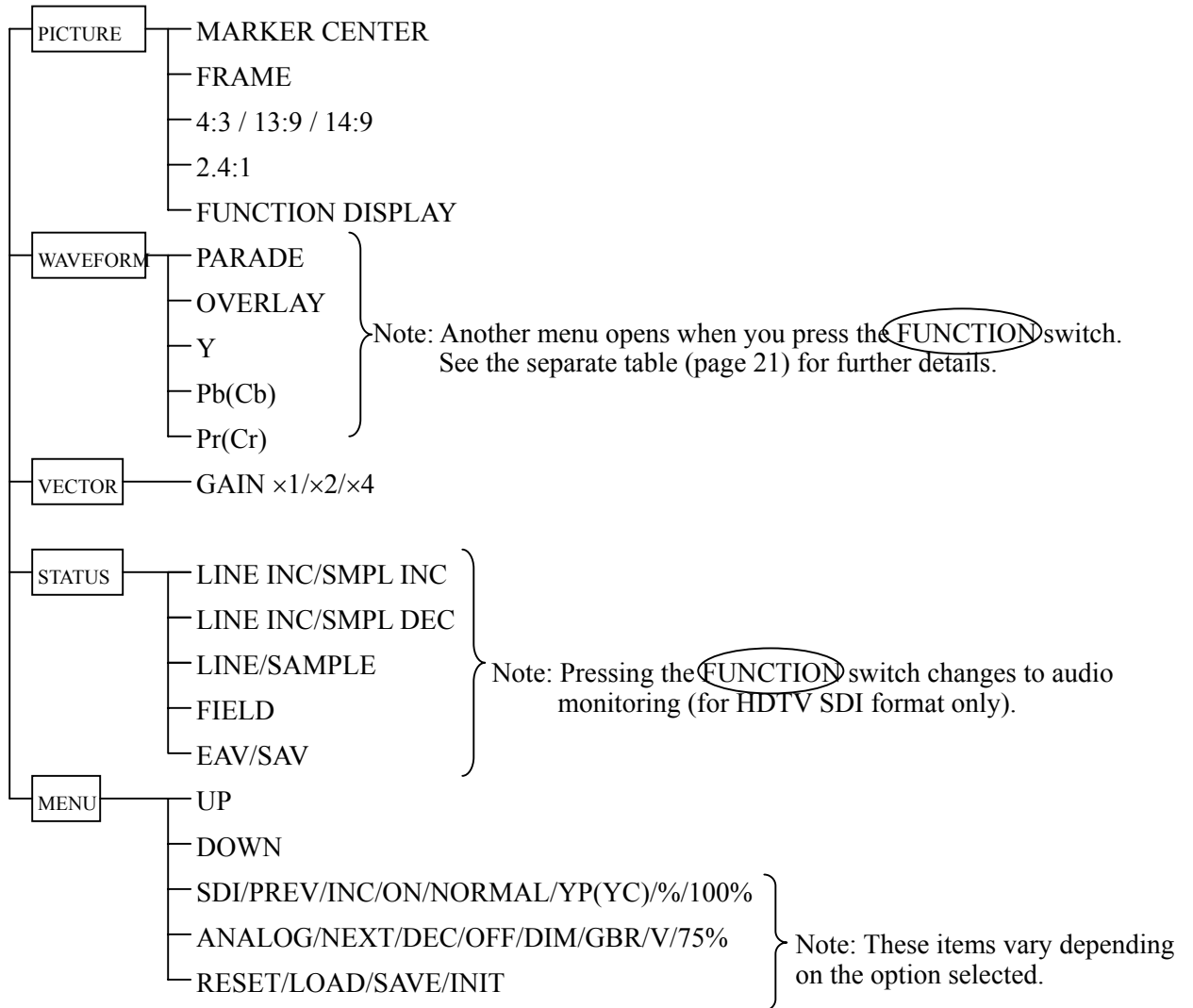

- When **LINE SEL** Switch Is Pressed

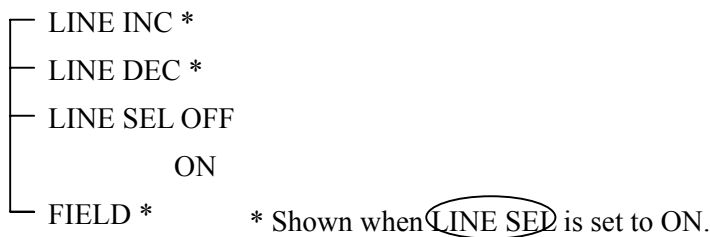

● When **FUNCTION** Switch Is Pressed in Waveform Mode

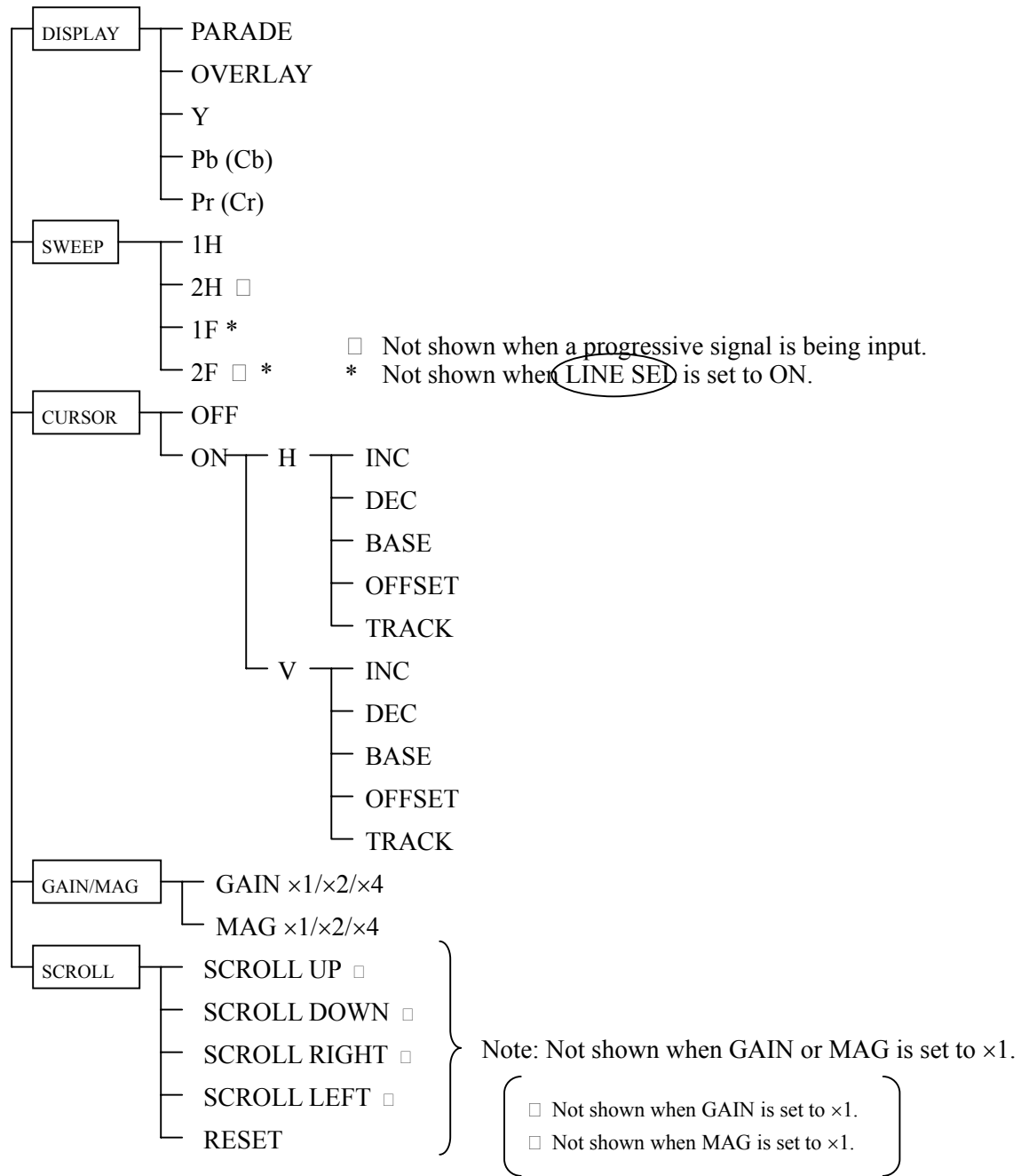

4.4 Installing and Anchoring the Monitor

This monitor has holes for 3/8" screws on both its top and bottom. Use them to secure the monitor to a camera tripod or arm, etc. To mount the monitor in a rack, use the optional* brackets.

* For further details on the optional accessories, see Chapter 6, Section 6.2, "Optional Accessories."

CHAPTER 5 MAIN SPECIFICATIONS

5.1 Input Formats

You can set the following input formats in the menu mode. The monitor automatically recognizes the frame rate (e.g., 60/59.94 or 24/23.98).

Format		Frame Rate [Hz]	Active Line per Frame	Total Line per Frame	Samples per Active Line	Samples per Total Line	Line Frequency [kHz]	Scanning
1035/60i <input type="checkbox"/>	1035/59.94i	30/1.001	1035	1125	1920	2200	33.72	Interlace
	1035/60i	30	1035	1125	1920	2200	33.75	Interlace
1080/60i <input type="checkbox"/>	1080/59.94i 1080/29.97sF	30/1.001	1080	1125	1920	2200	33.72	Interlace Segmented Frame
	1080/60i 1080/30sF	30	1080	1125	1920	2200	33.75	Interlace Segmented Frame
1080/30p <input type="checkbox"/>	1080/29.97p	30/1.001	1080	1125	1920	2200	33.72	Progressive
	1080/30p	30	1080	1125	1920	2200	33.75	Progressive
1080/25sF (1080/50i) <input type="checkbox"/>	1080/25sF 1080/50i	25	1080	1125	1920	2640	28.13	Segmented Frame Interlace
1080/25p <input type="checkbox"/>	1080/25p	25	1080	1125	1920	2640	28.13	Progressive
1080/24sF <input type="checkbox"/>	1080/23.98sF	24/1.001	1080	1125	1920	2750	26.97	Segmented Frame
	1080/24sF	24	1080	1125	1920	2750	27.00	Segmented Frame
1080/24p <input type="checkbox"/>	1080/23.98p	24/1.001	1080	1125	1920	2750	26.97	Progressive
	1080/24p	24	1080	1125	1920	2750	27.00	Progressive
720/60p <input type="checkbox"/>	720/59.94p	60/1.001	720	750	1280	1650	44.96	Progressive
	720/60p	60	720	750	1280	1650	45.00	Progressive
720/24p <input type="checkbox"/>	720/23.98p	24/1.001	720	750	1280	4125	17.98	Progressive
	720/24p	24	720	750	1280	4125	18.00	Progressive
525/60i <input type="checkbox"/>	529/59.94i	59.94	487	525	720	858	15.73	Interlace

HDTV System	Format No.	Specifications
BTAS-001B/2B/4B standard-compliant 1080/60i and 1035/60i	<input type="checkbox"/>	Number of scanning lines: 1035/1125, 1080/1125
		Number of samples: 1920/2200
		Field frequency: 60 Hz or 59.94 Hz
		Line frequency: 33.75 kHz or 33.72 kHz
SMPTE 274M standard-compliant 1080/60i, 1080/24p, 1080/24sF, 1080/30p, 1080/30sF, 1080/25p, 1080/25sF, and 1080/50i	<input type="checkbox"/>	Number of scanning lines: 1080/1125
		Number of samples: 1920/2200, 1920/2750, 1920/2640
		Field frequency: See the table above.
		Line frequency: See the table above.
SMPTE 296M standard-compliant 720/60p and 720/24p	<input type="checkbox"/>	Number of scanning lines: 720/750
		Number of samples: 1280/1650, 1280/4125
		Frame frequency: See the table above.

		Line frequency: See the table above.
SDTV System	Format No.	Specifications
SMPTE 259M standard-compliant 525/60i	□	Number of scanning lines: 487/525
		Number of samples: 720/858
		Field frequency: See the table above.
		Line frequency: See the table above.

5.2 Methods of Signal Input

Input Method	Specifications
HDTV SDI	BTAS-004B, BTAS-006B, SMPTE 292M or SMPTE 299M standard-compliant 10-bit NRZI SDI signals
	1080/60i, 1035/60i, 720/60p, 720/24p, 1080/24sF, 1080/24p, 1080/30sF, 1080/30p, 1080/25sF and 1080/25p
	Automatic tracking of field frequency (e.g., 60 and 59.94 Hz)
	Monitor output available
HDTV Y/Pb/Pr	BTAS-001B, SMPTE 274M or SMPTE 296M standard-compliant
	1080/60i, 1035/60i, 720/60p, 720/24p, 1080/24sF, 1080/24p, 1080/30sF, 1080/30p, 1080/25sF and 1080/25p
	Automatic tracking of field frequency (e.g., 60 and 59.94 Hz)
	Y_On Sync used for synchronization
SDTV SDI	SMPTE 259M standard-compliant 10-bit NRZI SDI signals
	525/60i; field frequency: 59.94 Hz
	Monitor output available

5.3 Methods of Display

Display Method	Specifications
Liquid crystal	Low-temperature polysilicon TFT liquid crystal
Screen size	6 inches (approx. 13 cm)
Resolution	1024 (H) × 768 (V) pixels
Resolving power	202 ppi (pixels per inch)

5.4 General Specifications

Operating Environment and Ratings

Operating temperature range	5 to 40°C
Operating humidity range	30% to 80% RH (no condensation)
Rated voltage	10 to 18 V DC
Power consumption	18.5 W
Service life	Average 10,000 hours (with LCD-backlight on)
Dimensions	175 (W) × 133 (H) × 40.7 (D) mm (excluding protrusions)
Weight	Approx. 1.0 kg

5.5 Initial Settings

- Switches with Fixed Functions

Switch	Setting
MODE	Picture mode
FREEZE	Update
LINE SEL	OFF
OVERLAY	OFF
FUNCTION	DISPLAY

- Picture Mode

Function	Setting
F1 (CENTER)	Center marker OFF
F2 (FRAME)	Frame marker OFF
F3 (4:3/13:9/14:9)	4:3/13:9/14:9 marker OFF
F4 (2.4:1)	2.4:1 marker OFF
F5 (FUNCTION DISPLAY)	Function menu display ON

- Waveform Mode

Function	Setting
DISPLAY (F1)	Overlay; Show all channels
SWEEP (F2)	1H
CURSOR (F3)	OFF
GAIN/MAG (F4)	GAIN×1, MAG×1
SCROLL (F5)	Not shown

- Vectorscope Mode

Function	Setting
F1	Not shown
F2	Not shown
F3	Not shown
F4	Not shown
F5 (GAIN)	GAIN ×1

- Status Mode (Data Dumping Function)

Function	Setting
F1 (LINE INC)	The selected line is 0001 (default) in field 1.
F2 (LINE DEC)	
F3 (LINE/SAMPLE)	LINE
F4 (FIELD)	Field switching: Enabled.
F5 (EAV/SAV)	SAV

- Menu Mode

Function	Setting
CHANNEL	SDI
FORMAT	1080/60i
BRIGHT	0.0%
CONTRAST	100.0%
Pb (Cb), Pr (Cr), CHROMA	100.0%
CHROMA ON/OFF	ON

OVERLAY CONT	NORMAL
WAVEFORM	YP (YC)
SCALE	%
COLOR BAR	100%

● Rear-panel DIP Switch

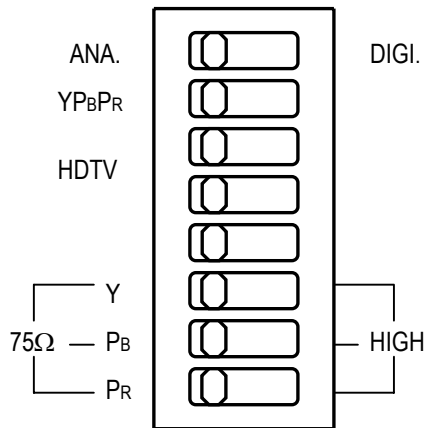

Function	Setting
ANA./DIGI.	Left - Keep fixed in this position.
Y _P B _P R _P	Left (Y/Pb/Pr position)
HDTV	Left - Keep fixed in this position.
—————	Left - Keep fixed in this position.
—————	Left - Keep fixed in this position.
75Ω_Y/HIGH	Left (75Ω_Y position)
75Ω_P _B /HIGH	Left (75Ω_P _B position)
75Ω_P _R /HIGH	Left (75Ω_P _R position)

Note: You are not allowed to use the rear-panel DIP switch for other purposes than switching between the 75 Ω and HIGH options. When inputting HDTV analog signals, change the CHANNEL setting from SDI to ANALOG in the menu mode.

5.6 Dimensional Drawings

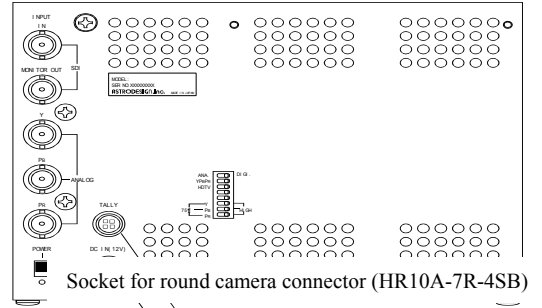
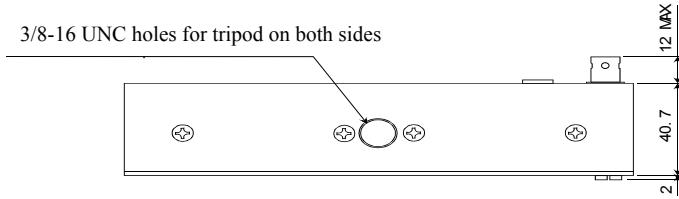

Plug for round camera connector (HR10A-7R-4PB)

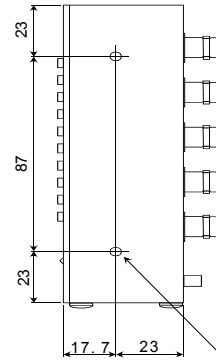
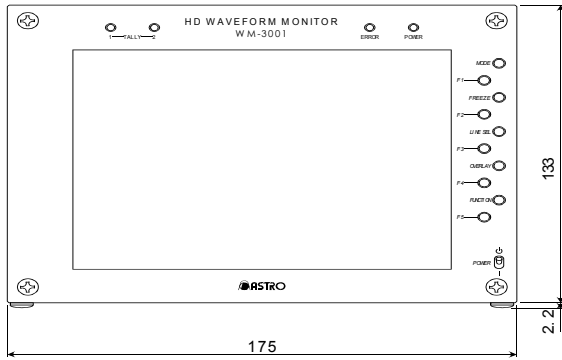

Pair of M4 holes for rack mounting bracket on both sides

CAUTION: Do not use any other screw than the supplied accessory screws for the mounting holes. Otherwise, the monitor may malfunction.

CHAPTER 6 STANDARD AND OPTIONAL ACCESSORIES

6.1 Standard Accessories

WM-3001 instruction manual	1 copy
Round camera connector/ cannon connector conversion cable	1 pc
1/4" conversion screw (*5)	2 pcs
M4 screw (*6)	4 pcs
LCD protection panel (*7)	1 pc

*5: The 1/4" conversion screws are adapters for converting the 3/8" German-standard thread to the 1/4" international-standard thread.

*6: The M4 screws are used to attach the rack-mounting brackets.

When attaching the brackets, do not use any other screw than the supplied accessory screws.

Otherwise the monitor may malfunction.

*7: The LCD is a precision instrument. It is therefore advisable to attach the LCD protection panel before use.

6.2 Optional Accessories

Rack-mounting brackets, cables, and other optional accessories are available for the LCD and main units of the WM-3001. New optional accessories are released from time to time. Contact your Astrodesign sales office or representative for the latest information.

Product	Model/Part Number	Description
WM-3001	WM-3001	Main unit
AC/DC adapter	DM-3000A-03	
Single rack-mounting bracket	DM-3000A-04	
Double rack-mounting bracket	DM-3000A-05	
Anton Bauer battery adapter	DM-3000A-06	
Carrying case	DM-3000A-07	
Shading hood	DM-3000A-08	
DC-input extension cable	DM-3000A-09	Cable for DC input with 4-pin round camera connector
Battery adapter for V mount	DM-3000A-10	
LCD protection acrylic plate	DM-3000A-12	

Attaching the LCD Protection Panel Supplied as a Standard WM-3001 Accessory

- How to Attach the Protection Panel

- i) Take off the protective film from the LCD protection panel.
- ii) Insert the flaps of the protection panel into the upper and lower slots of the WM-3001 front panel.

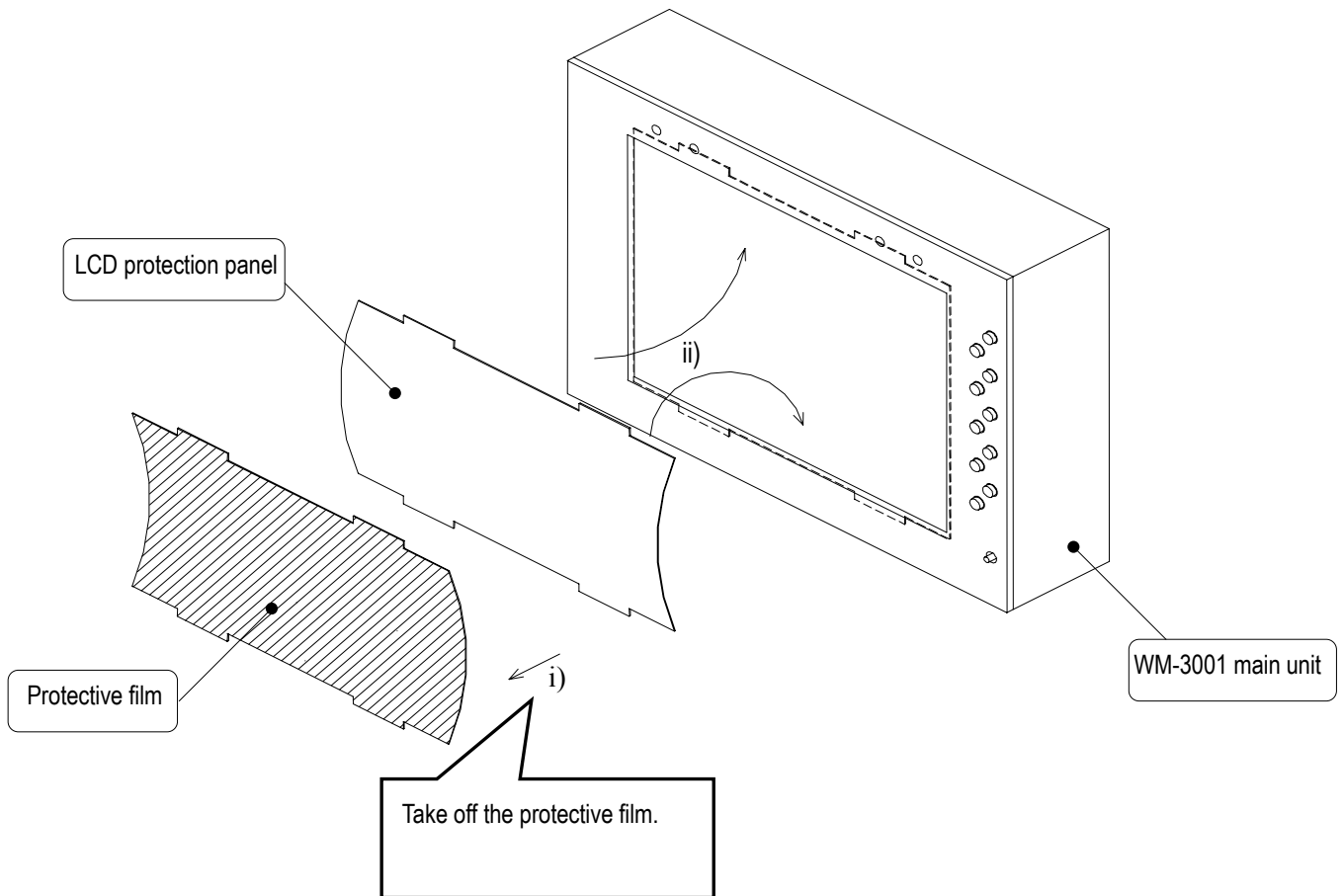

Data Sheet of DM-3000A-03 AC/DC Adapter

1. Overview

The DM-3000A-03 AC/DC adapter is used to receive a 100 V AC or 240 V AC supply of power and provides a 12 V DC power supply.

2. Using the Adapter

The AC/DC adapter has a cannon connector as its output terminal.

When using the AC/DC adapter to supply power to the DM-3000B portable LCD monitor, connect the conversion cable, which is attached to the main unit of the LCD monitor, to this adapter.

3. Electrical and Environmental Specifications

Rated output voltage	V	12 ±5%
Rated output current	A	3.0
Maximum output power	W	36
Input voltage	V AC	Rated range: 100 to 240
Input frequency	Hz	Ratings: 50/60
Efficiency	%	70 (MIN)
Operating ambient temperature	°C	0 to +40
Operating ambient humidity	%RH	10 to 90
Storage ambient temperature	°C	-10 to +70
Storage ambient humidity	%RH	5 to 95
Output plug pin assignments	Pin 1	GND
	Pin 2	NC
	Pin 3	NC
	Pin 4	POWER

Instructions on the Use of DM-3000A-04 Single Rack Mounting Brackets

1. Items of Bracket Kit

□ Mounting bracket

□ Single mounting bracket

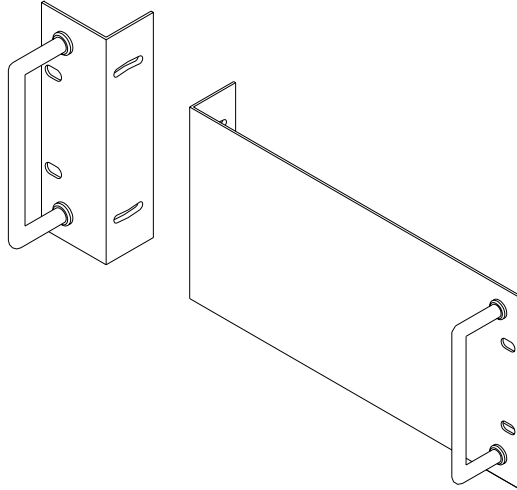

2. Mounting

Use the M4 bind-head screws to attach the mounting brackets to the monitor.

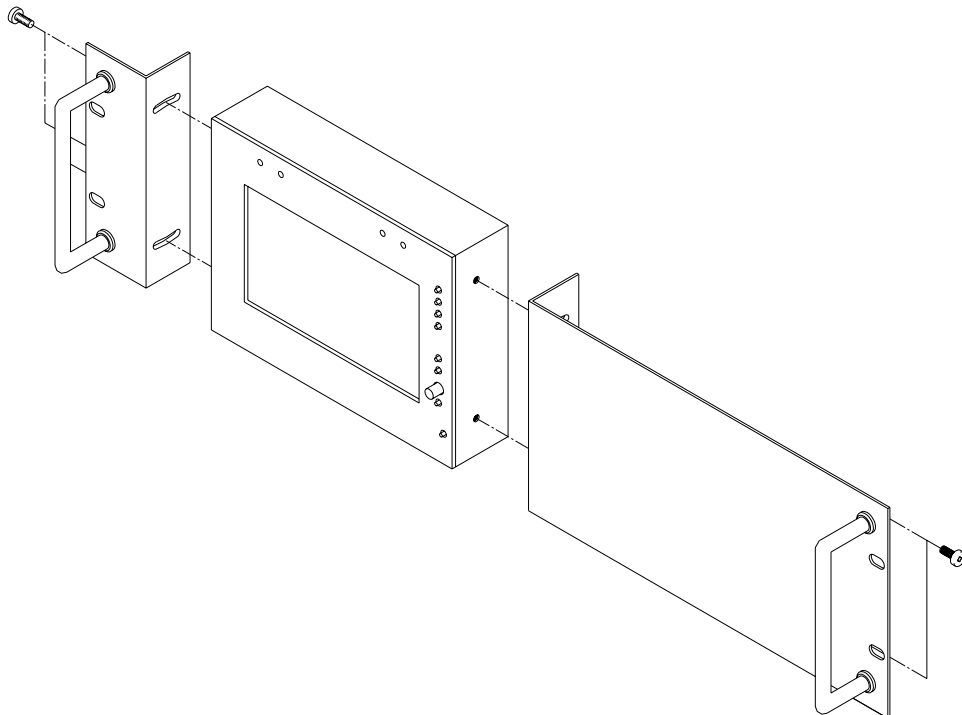

Instructions on the Use of DM-3000A-05 Double Rack Mounting Brackets

1. Items of Bracket Kit

- Mounting brackets: 2 pcs
- Joint brackets: 2 pcs
- M3 flat-head screws: 2 pcs

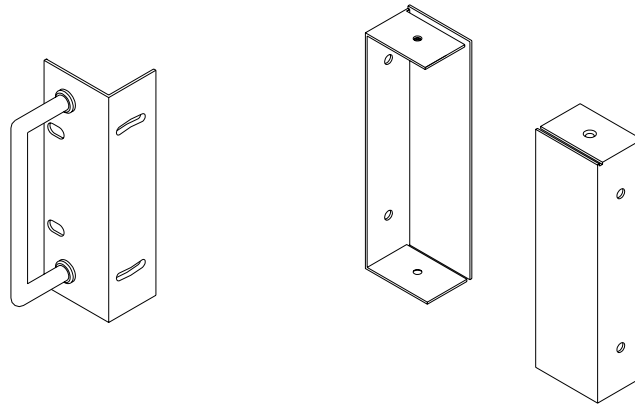

2. Mounting

Use the M4 bind-head screws to attach the mounting brackets to the monitor.

Attach the joint brackets upside down to the monitor. Then, fasten the brackets with the accessory M3 flat-head screws from the top and bottom.

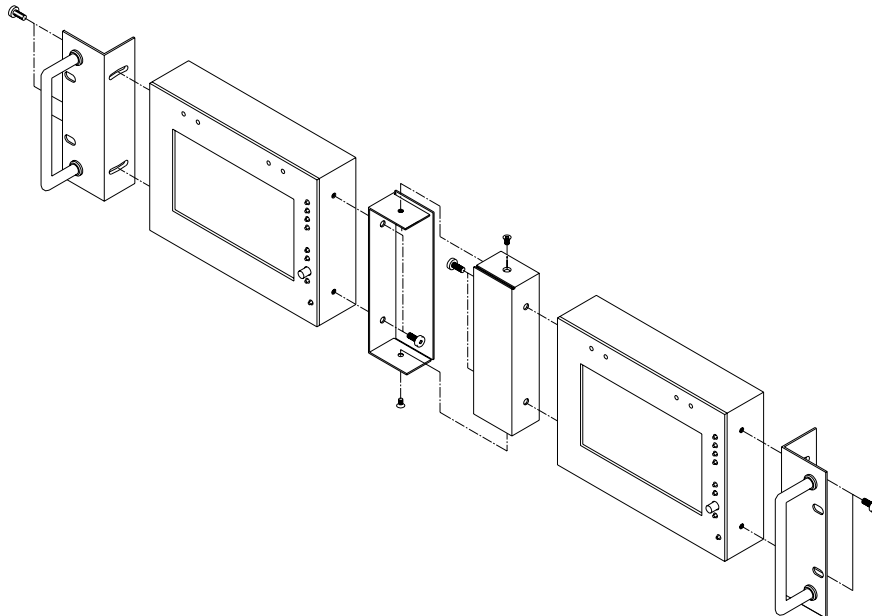

Instructions on the Use of DM-3000A-08 Shading Hood

Mounting

1. Attach the Velcro fasteners packed with the monitor onto both sides of the monitor.

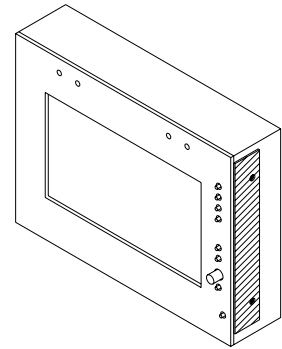

2. Attach the shading hood to the monitor, as shown on the right.

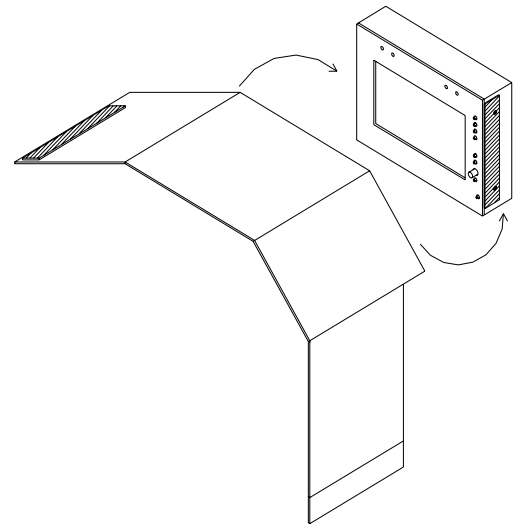

2. Close the ends of the shading hood by joining the Velcro fasteners.

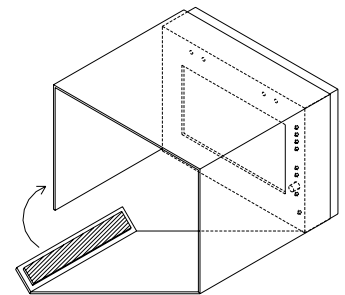

NOTICE

- **An incorrectly collated manual or a manual with missing pages will be replaced.**
- **All copyrights pertaining to this product are the property of Astrodesign.**
- **This manual may not be copied in whole or in part without written permission.**
- **The contents of this manual are subject to change without prior notice due to improvements.**
- **The manufacturer will not be liable for any effects caused by incorrect operation.**
- **All inquiries concerning this product should be addressed to your dealer or to the manufacturer at the contact numbers given below.**
- **The products and product names mentioned in this manual are the trademarks and registered trademarks of the companies concerned.**

ASTRODESIGN, INC.

2-6-17 Haramachi, Meguro-ku, Tokyo 152-0011

Tel: +81-3-5720-5835, Fax: +81-3-5720-5835